

**ACTUAL SIZE**

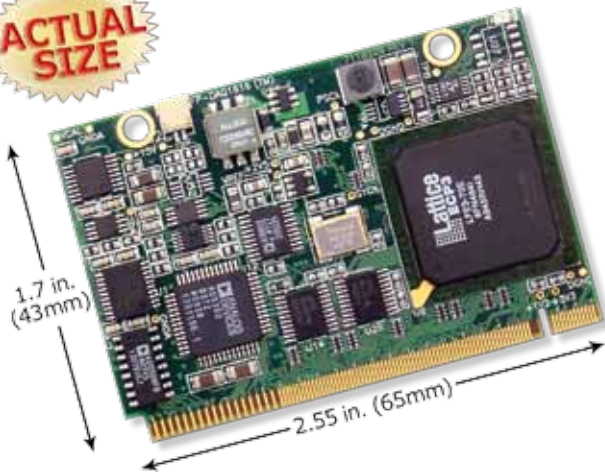

**FeaturePak** is an exciting new embedded system expansion standard, originated by Diamond Systems, that provides a compact, low-cost method of adding I/O to board-level embedded computers. FeaturePak modules can be used as snap-in customization modules for commercial, off-the-shelf single-board computers (SBCs) and computer-on-module (COM) baseboards, or as functional blocks on fully-custom embedded electronics.

This new mezzanine-style embedded I/O expansion standard is highly synergistic with existing and emerging bus-, I/O-, chip- and board-level technologies. It leverages the latest high-speed serial expansion standards—such as PCI Express and USB—and is compatible with a wide range of current and future processors, including both x86 and RISC architectures.

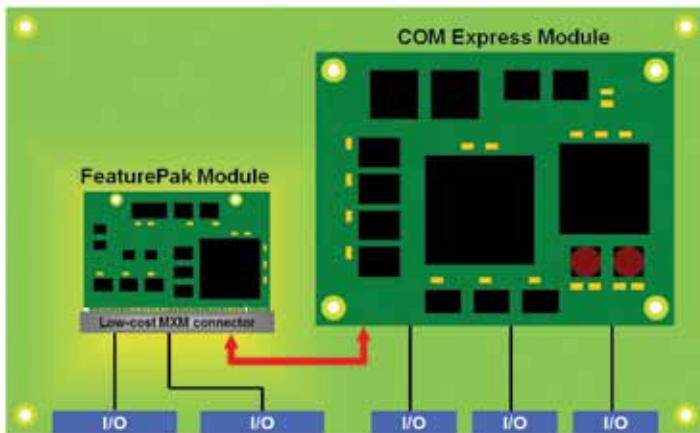

FeaturePak on COM Express baseboard

## WORLD'S SMALLEST PCI EXPRESS OPEN ARCHITECTURE EMBEDDED I/O STANDARD

### Key Features

- ◆ Compact, low profile form-factor—0.6x the size of a credit card!
- ◆ Single low-cost connector integrates all host and external I/O signals
- ◆ Provides up to 100 I/O points per module
- ◆ Leverages industry-standard buses such as PCI Express, USB, and SMBus
- ◆ Host form-factor and processor agnostic
- ◆ Coexists with PC/104, SUMIT, Qseven, ETX, XTX, COM Express, etc.
- ◆ Multiple FeaturePak modules may be present within one system
- ◆ Rugged and reliable
- ◆ Open industry standard

### Key Benefits

- ◆ Shortens time-to-market
- ◆ Reduces board-level development costs and risks
- ◆ Simplifies system design
- ◆ Eliminates cables, resulting in higher reliability, lower cost, and faster assembly
- ◆ Enables scalable and reconfigurable system design
- ◆ Enables easy product upgrades
- ◆ Protects from component obsolescence
- ◆ Encapsulates intellectual property
- ◆ Suitable for SBCs, baseboards, and proprietary all-in-one hardware designs
- ◆ Ideal for rapid-prototyping through high-volume applications
- ◆ Ideal format for silicon vendor reference designs
- ◆ Open standard increases market acceptance

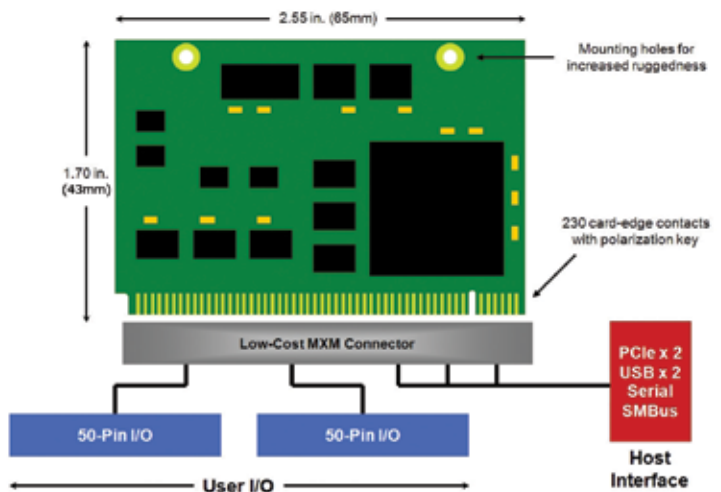

### FeaturePak modules Enable Faster and More Flexible Baseboard Design

With their compact size and standardized connector, FeaturePak modules are easy-to-use macrocomponents that target a wide range of embedded applications. Embedded computer design can be greatly simplified by treating complex I/O subsystems as components, just as various types of COMs (computer-on-modules)

allow designers to treat the core embedded computing functions as a plug-in building block. This macrocomponent approach greatly accelerates design cycles, and also enables the creation of reconfigurable and upgradable products.

# FEATUREPAK-DAQ1616

## FeaturePak Analog I/O Module with 2MHz A/D and Autocalibration

- ◆ 16 12-bit analog inputs with 2MHz maximum sampling rate
- ◆ Programmable input ranges, polarity, and mode
- ◆ 16K sample A/D FIFO with programmable threshold
- ◆ 16 16-bit analog outputs with programmable range and polarity
- ◆ Autocalibration circuit with precision reference voltages
- ◆ 56 programmable digital I/O
- ◆ 2 32-bit counter/timers for A/D timing and general purpose use
- ◆ 4 24-bit pulse-width modulator circuits
- ◆ Watchdog timer with system reset capability
- ◆ 1 PCI Express x1 lane host interface
- ◆ FeaturePak form-factor compliant
- ◆ -40°C to +85°C operating temperature
- ◆ Universal Driver software support



**FP-DAQ1616** is a FeaturePak I/O card featuring Diamond's newest and fastest analog I/O technology and a PCI Express interface. This board offers 12-bit A/D sampling at 2MHz, supported with an expanded 16K-sample FIFO for reliable data collection in any operating system. Analog output capability has been expanded to 16 16-bit channels with programmable output ranges. All analog I/O features are enhanced with our industry-leading autocalibration technology, featuring independent calibration factors for each input and output range to guarantee maximum accuracy across all operating modes and the entire operating temperature range.

Digital I/O features include 7 8-bit ports with both bit-wide and byte-wide direction control, 2 32-bit up/down counter/timers with programmable input source and gate, 4 24-bit pulse-width modulation circuits with 0-100% duty cycle, and a watchdog timer. Universal Driver software support is included for Linux, Windows XP/Embedded Standard, and Windows CE.

The board is available in analog I/O and analog out-only configurations.

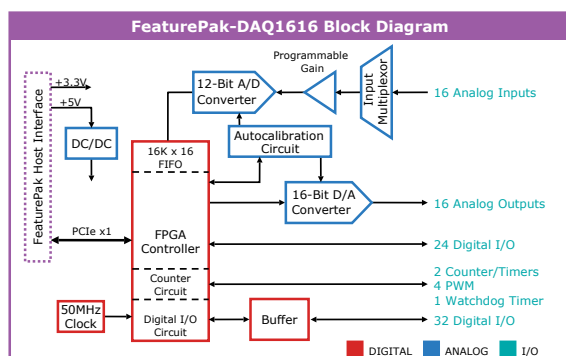

### Available Models

<b>FP-DAQ1616</b>	FeaturePak 2MHz Analog I/O and Digital I/O Module
-------------------	---

# FEATUREPAK-GPIO96

## FeaturePak Programmable Digital I/O Module with Customizable Personality

- ◆ FPGA- based design with in-the-field reconfigurability
- ◆ 96 buffered, programmable digital I/O
- ◆ Byte-wide and bit-wide port direction control
- ◆ 3.3V and 5V user-selectable I/O configuration
- ◆ 8 32-bit counter/timers
- ◆ 4 24-bit pulse-width modulators
- ◆ Watchdog timer with system reset capability
- ◆ 50MHz system clock
- ◆ 1 PCI Express x1 lane host interface
- ◆ FeaturePak form-factor compliant
- ◆ -40°C to +85°C operating temperature
- ◆ Universal Driver software support



**FP-GPIO96** is a FeaturePak general purpose I/O module using a high-capacity (700K gate equivalent) PCI Express FPGA for maximum density and flexibility. The base hardware configuration features 96 digital I/O lines grouped into 12 8-bit ports. All ports have I/O buffers to protect the FPGA and offer user-selectable 3.3V or 5V logic drive levels. The ports are organized into a combination of byte-wide, nibble-wide, and bit-wide direction control for maximum flexibility and application compatibility.

The built-in FPGA personality provides multiple configuration options. All 96 I/O lines may be used in common I/O mode; Six of these ports can be reconfigured to enable an array of additional features, including 8 32-bit up/down counter/timers with programmable input source and gate, 4 24-bit PWM circuits with 0-100% duty cycle capability, interrupt/latched mode operation, and even a watchdog timer feature.

The flash-based design enables easy field upgrades using a Diamond-provided software utility (no cable or 3rd party software required!) as well as custom code development. Universal Driver software support is included for Linux, Windows XP/Embedded Standard, and Windows CE.

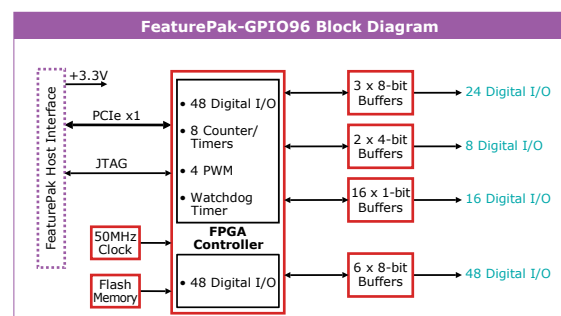

### Available Models

<b>FP-GPIO96</b>	FeaturePak Programmable GPIO Module with standard personality
------------------	---